

ITEM NO.	PART NUMBER	DESCRIPTION	QTY.
1	E-208106	HRC-330-PV90 V-Cradle	1
2	K040455	M6 x 1.0 x 12 Socket FCHS	3
3	K040533	M6 x 1.0 x 20 HHCS	6
4	K040721	Hex nut, Style 1, M6 x 1	9
5	K041118	M6 Lock Washer	9
6	P-60088	330lb hydraulic lift cart	1

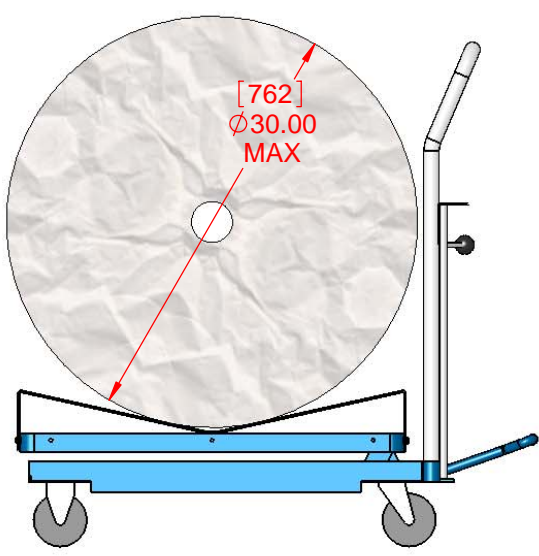

Release handle for lowering load

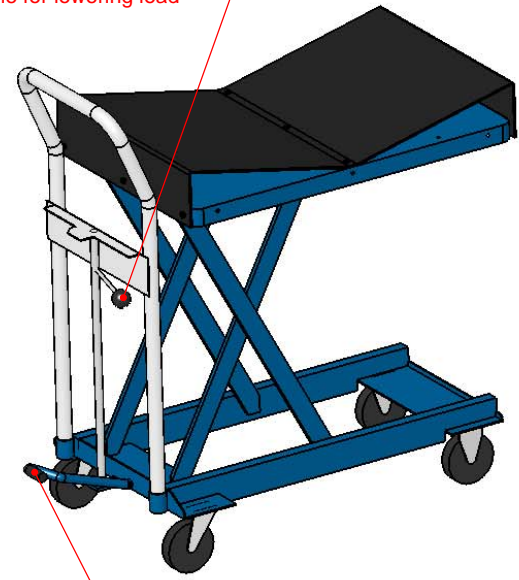

Foot pump for lifting load

MAX roll weight: 330lb (150kg)

MAX roll ϕ : 30" (762mm)

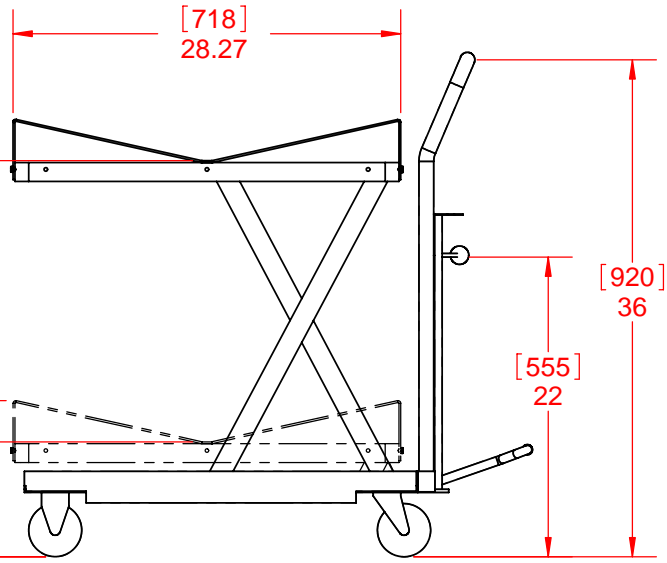
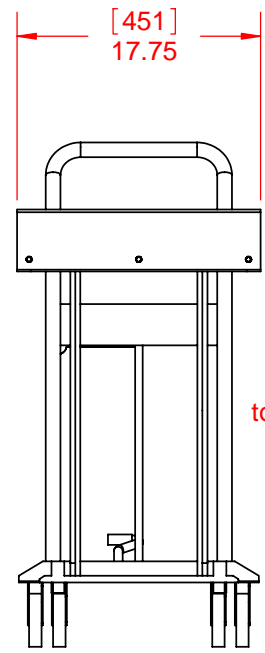

[213]
8.38
MIN height
to bottom of V-cradle

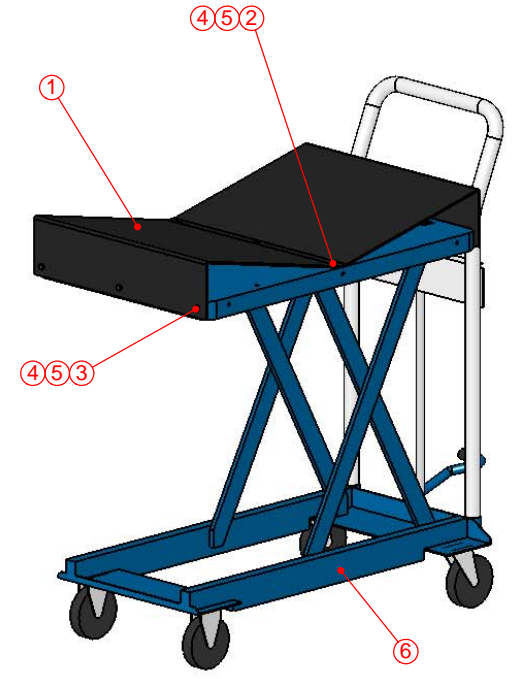

THE INFORMATION CONTAINED
IN THIS DRAWING IS THE SOLE
PROPERTY OF SCHLUMPF INC.
ANY REPRODUCTION IN PART OR
AS A WHOLE WITHOUT WRITTEN
PERMISSION OF SCHLUMPF INC.
IS PROHIBITED.



SIZE DO NOT SCALE DRAWING
DATE PRINTED WEIGHT (lb)
5/7/2008 127.2

15 Enterprise Drive; Windham, ME 04062 U.S.A.
Tel: 207-893-1903 Fax: 207-893-1905
E-Mail: mail@schlumpf-inc.com URL: www.schlumpf-inc.com

DRAWN BY
Matthew Skelton

LAST REVISION DESCRIPTION

MODEL
HRC-330-PV90 hydraulic lift cart

PART. NO.
M-100208