

LogiQ - easy and smooth handling of quarter pallets

The quarter pallet lifters, LogiQ 200 and LogiQ 300, are indispensable partners, when transporting quarter pallets in e.g. supermarkets, storage and packing areas, and gas stations. Quarter pallets are often used for the commonly used display pallets, and LogiQ 200 and LogiQ 300 are therefore perfect when transporting display pallets to the location of display in the shop.

LogiQ 200 and LogiQ 300 are very manoeuvrable, and can operate everywhere. The handles have ergonomically correct gripping angles, ensuring the user a relaxed hold. The wheels ensure a comfortable and noiseless transport - and are gentle to the fine floor and flagstone layer in the customer areas.

LogiQ 200 is designed for lifting and moving quarter pallets to the location of display. LogiQ 300 is designed for lifting quarter pallets from/to a EUR pallet and moving them to the requested location in the shop.



Technical Specifications

The quarter pallet lifters can be used for many kinds of quarter pallets (e.g. display pallets) and are available in two models:

LogiQ 200

- lifting and moving quarter pallets
- the pallets are lifted from the floor with only one handle stroke

LogiQ 300

- lifting quarter pallets to/from a EUR pallet, and transporting of these
- hydraulic pump: Lifting the pallet from the floor only requires a half pump stroke. Only 5 pump strokes are required to lift to the top

Optimum user-friendliness and safety

- high manoeuvrability / low own weight
- CE-marking
- foot protection



LogiQ 300 has a hydraulic pump, minimising the number of pump strokes.



The ergonomically correct gripping angles ensure the user a relaxed grip.



Parking brake on LogiQ 300.

Product (measured in inch)	LQHM 200	LQHM 300
Capacity in lbs.	440	660
Lifting height h_3	4.5	12.4
Fork length l	23.5	23.5
Overall height h_1	18.5	24.6
Overall width b_1	18	20
Length without forks l_2	10.25	11.75
Overall length l_1	33.9	35.5
Lowered height h_{13}	3.25	3.25
Fork width e	8	8
Fork thickness s		1.75
Overall height with handle h_{14}	40.95	46
Weight	49 lbs.	104 lbs.



LogiQ 300 can handle the upper quarter pallet without problems.



A quarter pallet is lifted from a EUR pallet with LogiQ 300 and can be moved to the location of display in the shop.

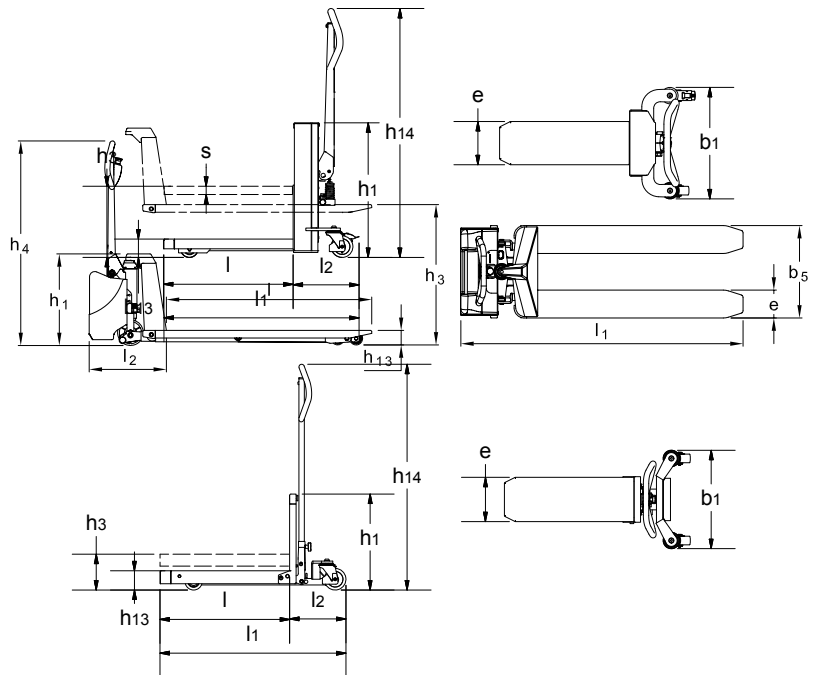

We also offer tailor-made solutions.

Please ask for further information or visit our website www.interthor.com