

MT2HV11DC
300 lbs [135 kg]

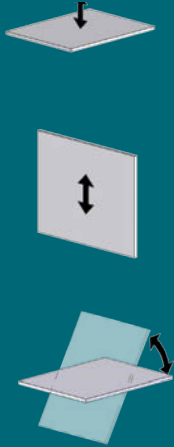

MANUAL TILTER 300

This Powr-Grip® vacuum lifter provides an economical way for a single person to lift and tilt loads.

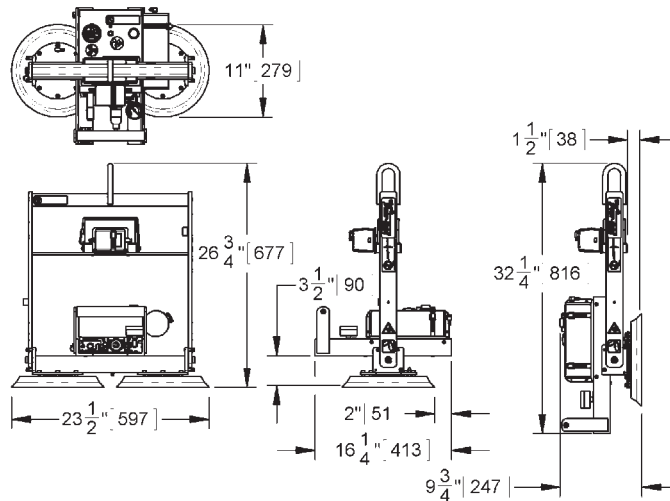

Shown with optional Dual Vacuum System

**THE ORIGINAL
 & TRUSTED NAME
 IN VACUUM LIFTING
 EQUIPMENT**



908 West Main - P.O. Box 368
 Laurel, Montana 59044 U.S.A.
 406.628.8231 (phone)
 406.628.8354 (fax)

800.548.7341
www.WPG.com

Standard Pad Spread	11" x 23½" [279 x 597 mm]
Number / Size of Pads	2 / 10" [25 cm] dia. lipped
Load Capacity (On smooth, nonporous surfaces. Please contact us for recommendations on other surfaces.)	300 lbs [135 kg]
Unit Weight	51 lbs [24 kg]
Standard Operating Power	12 volts DC, 10 amps (Other voltages available)
Apply	3 seconds (approximately)
Release	3 seconds (approximately)
Load Movement	Manual tilt, 90° between upright and flat
Standard Features	Low vacuum warning light Low vacuum warning buzzer Vacuum gauge Vacuum line filter Vacuum reserve tank On-board battery and charger Battery energy gauge
Available Options	Dual vacuum system (EO10DVS) Flat lift model (FL2HV11DCS) Closed cell foam pad rings (FRHV11) Movable control pendant (EO9RP) Air (venturi) power system (MT2HV11AIRS) Alternative pad spread and capacities
Design Standards (See www.WPG.com for more information.)	ASME B30.20 - 2006 (BTH-1 Design Category "B", Service Class "0") CE



Products are manufactured under an
 ISO 9001 quality management system

Wood's Powr-Grip products are sold
 through authorized dealers.

Environmental conditions can affect product performance and longevity; consult the product instructions on
 www.WPG.com or contact a Technical Sales Representative for more information.
 Based on product information at time of publication.

MT1HV11DC
150 lbs [70 kg]



MANUAL TILTER 150

With a single vacuum pad for quick attachment and release, this Powr-Grip® vacuum lifter enables ergonomic handling of heavy loads by a single person.

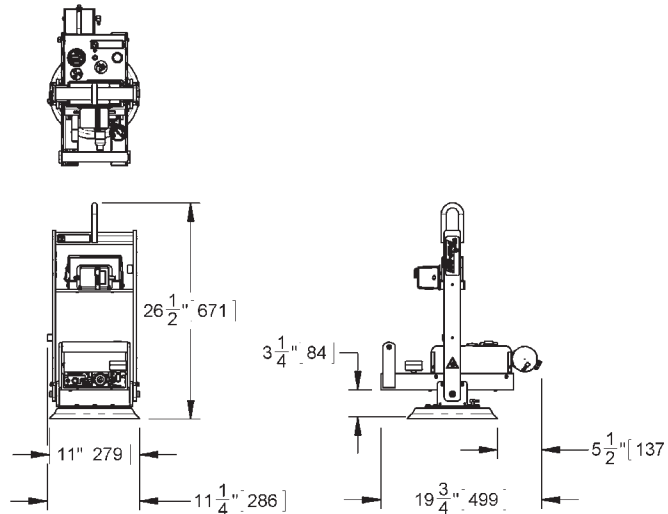

**THE ORIGINAL
 & TRUSTED NAME
 IN VACUUM LIFTING
 EQUIPMENT**



908 West Main - P.O. Box 368
 Laurel, Montana 59044 U.S.A.
 406.628.8231 (phone)
 406.628.8354 (fax)

800.548.7341
www.WPG.com

Standard Pad Spread	11" x 11" [279 x 279 mm]
Number / Size of Pads	1 / 10" [25 cm] dia. lipped
Load Capacity (On smooth, nonporous surfaces. Please contact us for recommendations on other surfaces.)	150 lbs [70 kg]
Unit Weight	40 lbs [19 kg]
Standard Operating Power	12 volts DC, 10 amps (Other voltages available)
Apply	2 seconds (approximately)
Release	3 seconds (approximately)
Load Movement	Manual tilt, 90° between upright and flat
Standard Features	Low vacuum warning light Low vacuum warning buzzer Vacuum gauge Vacuum line filter Vacuum reserve tank On-board battery and charger Battery energy gauge
Available Options	Flat lift model (FL1HV11DCS) Closed cell foam pad rings (FRHV11) Movable control pendant (EO9RP) AC power system (MT1HV11ACS) Air (venturi) power system (MT1HV11AIRS)
Design Standards (See www.WPG.com for more information.)	ASME B30.20 - 2006 (BTH-1 Design Category "B", Service Class "0") CE

Environmental conditions can affect product performance and longevity; consult the product instructions on www.WPG.com or contact a Technical Sales Representative for more information.
 Based on product information at time of publication.

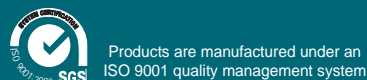

Wood's Powr-Grip products are sold through authorized dealers.