

**MR1611LDC**  
 2800 lbs [1270 kg]

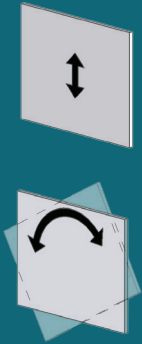

## MANUAL ROTATOR 2800

This high-capacity Powr-Grip® vacuum lifter features continuous 360° rotation, DC power and multiple configurations for installation or fabrication applications.

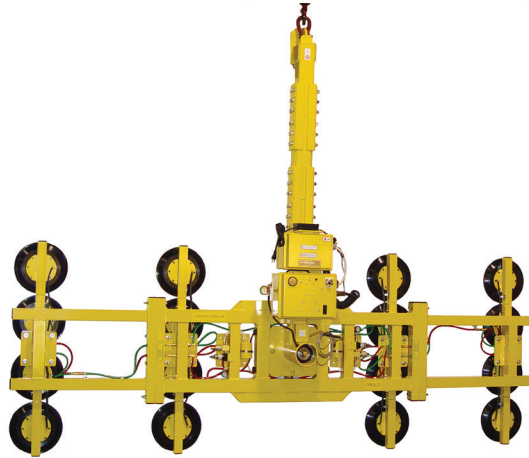

Shown with optional Dual Vacuum System



**THE ORIGINAL  
 & TRUSTED NAME  
 IN VACUUM LIFTING  
 EQUIPMENT**



908 West Main - P.O. Box 368  
 Laurel, Montana 59044 U.S.A.  
 406.628.8231 (phone)  
 406.628.8354 (fax)

**800.548.7341**  
**www.WPG.com**

Standard Pad Spread	Variable (see Frame Configurations and Capacities reverse side)
Number / Size of Pads	Variable / 11" [28 cm] dia. lipped (see Frame Configurations and Capacities reverse side)
Load Capacity	Variable (see Frame Configurations and Capacities reverse side)
Unit Weight	685 lbs [311 kg] (maximum)
Standard Operating Power	12 volts DC, 26 amps
Standard Charger Input Voltage	120 volts AC (Other voltages available)
Load Movement	Manual rotation, 360° edgewise, with locking at each quarter point
Standard Features	On-board battery and charger Battery energy gauge Green lift light Movable control pendant Vacuum gauge Vacuum reserve tank Vacuum line filter Removable lift bar extension Removable pad frame sections Removable pad arms Spring-mounted pads Blow-off for quick release
Available Options	Dual vacuum system (EO10DVS) Vacuum loss warning buzzer (EO3VLW) Short lift bar (LB11SLB) Remote control system (EO8RC3)
Design Standards (See www.WPG.com for more information.)	ASME B30.20 - 2006 (BTH-1 Design Category "B", Service Class "0")



Products are manufactured under an ISO 9001 quality management system

Wood's Powr-Grip products are sold through authorized dealers.

Environmental conditions can affect product performance and longevity; consult the product instructions on www.WPG.com or contact a Technical Sales Representative for more information.  
 Based on product information at time of publication.

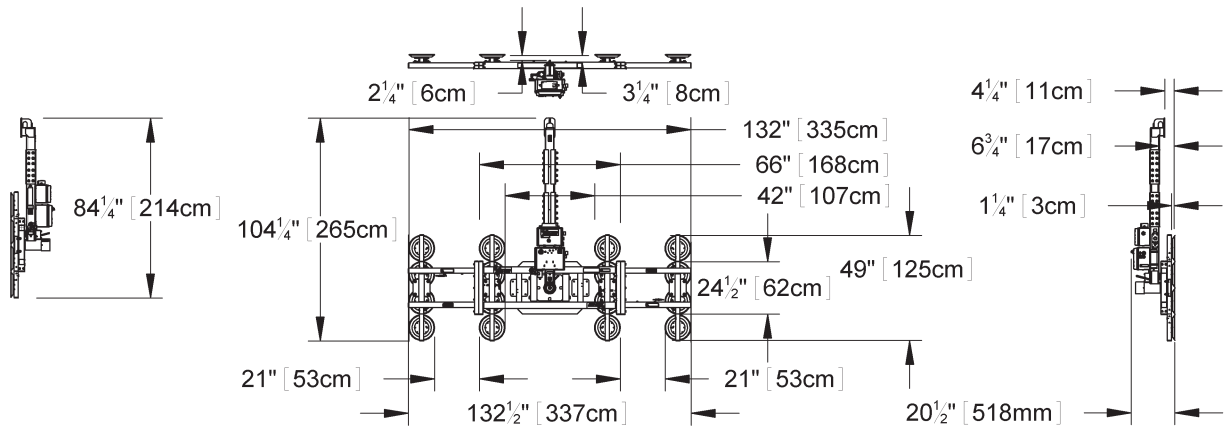

## FRAME CONFIGURATIONS AND CAPACITIES

