

WOODWORKING LIFTING SYSTEMS

Designed and manufactured for operation in the Woodworking and Furniture Industries

Palamatic
HANDLING
Systems
Limited

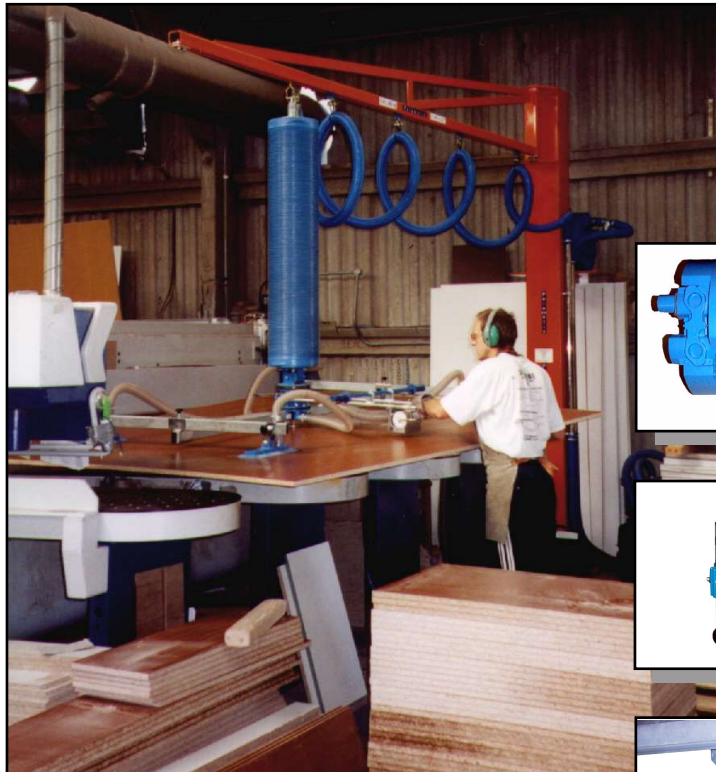

With features designed especially for the woodworking and furniture industries Palamatic's lifting systems offer:

- The ability to lift boards, doors, laminates, worktops, desk tops, pedestals, cabinets and flatpack furniture weighing between 20 kg - 300 kg
- Effortless, precise lifting power for a single operator for all types of machine loading and un-loading
- No threat of back strain. Increased productivity, and reduced threat of product damage
- Optional unique lift off feature offers instant release of the load when ready
- Two options of extension handle with additional heavy duty crossbar for high lift or long reach applications
- In-built safety feature prevents load release during power failure.

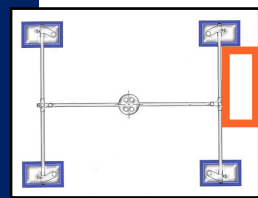
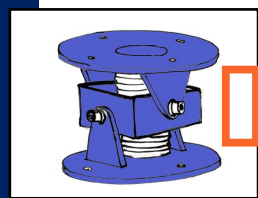
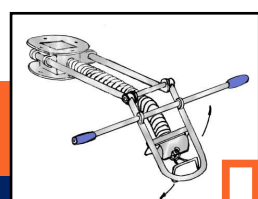
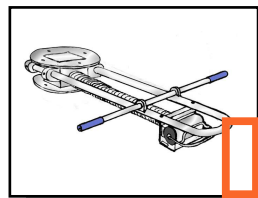

MARKET LEADERS IN DESIGN AND MANUFACTURE OF MATERIALS HANDLING EQUIPMENT

THE BENEFITS ACHIEVED:

VACUUM PUMP

Quiet, efficient, no-maintenance vacuum pumps capable of performing 24 hours a day at full vacuum DB(A) ratings 70-75

FILTER SYSTEMS

Palamatic's own manufacture units gives you the choice of one of three separate options to suit the working environment - from general workshop to high dust areas

LIFT TUBE ASSEMBLIES

Single and multi lift tube assemblies available with capacities for plywood and chipboard sheets weighing 20kg through to solid laminates of 300kg. Durable lift tubes are tested to over 100,000 continuous operations with no perceived damage.

HCL CONTROL HEAD OPTION

High capacity control heads with stayput or spring loaded lever valve to suit operator preference. Rigid extended handle places operator in most convenient position to handle load.

HCL EXTENSION OPTIONS

Choice of flexible extension handle allows high stacking of load.

UNIVERSAL JOINT

recommended for use with all HCL handling systems. Help prevent damage to lift tube and minimise maintenance costs.

END EFFECTORS

Widest range of standard and special end effectors available

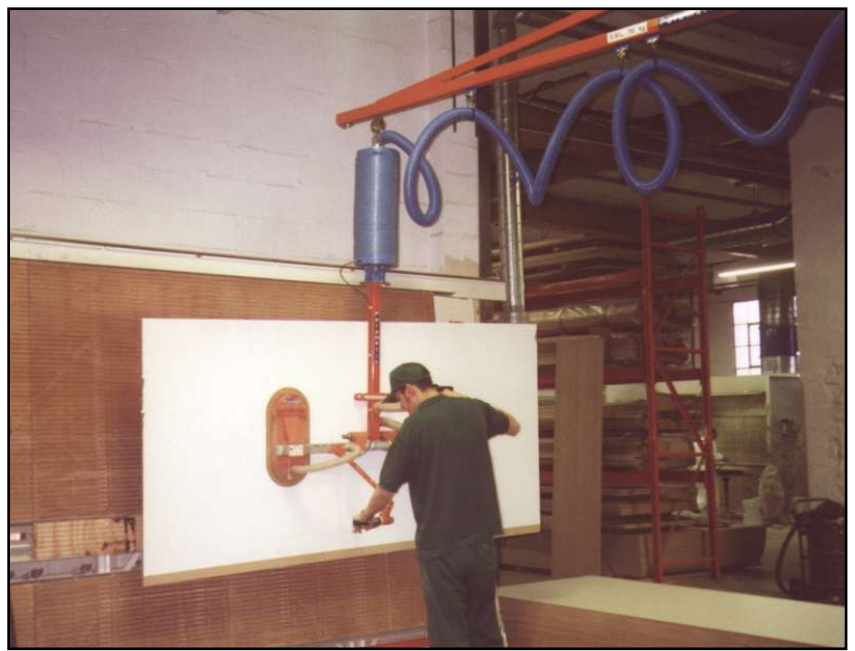

Specially designed systems also available for 90° or 180° turning

HEAD OFFICE
Palamatic Handling Systems
 Cobnar Wood Close
 Chesterfield Trading Estate
 Chesterfield
 Derbyshire. S41 9RO
 England

Tel: +44 (0) 1246 452054
 Fax: +44 (0) 1246 451379
 Email: sales@palamatic.com
 Web: www.palamatic.com

Palamatic Handling USA Inc
 PO Box 2020
 West Chester
 PA19380

Tel: +1 610 701-6350
 Fax: +1 610 701-6354
 Email: tcarney@chesco.com
 Web: www.palamaticusa.com

Palamatic Handling Systems France
 Tel: +33 299 860622
 Fax: +33 299 860810

Palamatic Handling Systems India
 Tel: +91 80 5484733
 Fax: +91 80 5485119
 Email: scorpio@bgl.vsnl.net.in

Distributors in:

Australia	Mexico
Belgium	New Zealand
Brazil	Norway
Canada	Puerto Rico
Czech Republic	Portugal
Denmark	Singapore
France	South Africa
Holland	Spain
India	Sweden
Ireland	UAE
Italy	USA
Malaysia	

Palamatic's worldwide sales network ensures that our expertise works for the company and its operatives

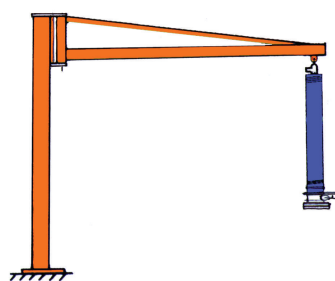

Fig 1

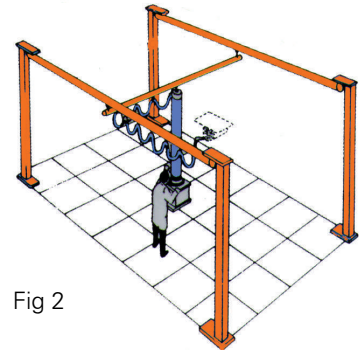

Fig 2

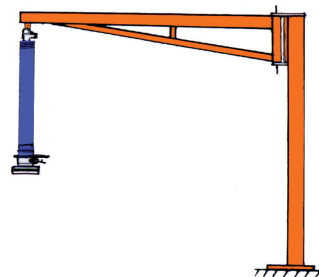
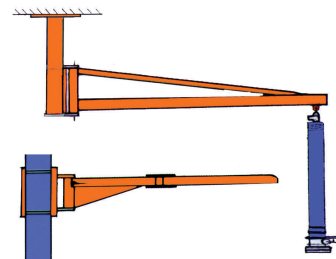

Fig 3



SUPPORT GANTRIES

Palamatic offer a full range of support gantry systems to suit every application requirement:

- Mono rail systems
- Swing jib with centre post ideal for most applications (Fig 1)
- H Track - when you need to cover a large working area (Fig 2)
- Articulated jibs and inverted jibs - ideal for low headroom and compact working areas (Fig 3)
- SWL Testing and Certification services available

We recommend on-site surveys to work out the best layout for your needs resulting in the most suitable support gantry system.

Introduced by: